

ADDENDUM NO.1

FY2020 Water and Drain Improvements
Project No. 20DPW07
Ayer DPW

This addendum amends and/or supplements the bid documents as indicated below. Only these items alter the Bid Documents; any verbal discussions or responses are hereby declared null and void.

Bidder shall acknowledge receipt of this addendum on the Form for General Bid.

Item No. 1. Revised Sheets C-2, C-3, and Section 00300 (Form for General Bid)

- a) Proposed Conditions Sheets C-2 and C-3 were revised to show the following:
 - i. Water service replacement for #8 Holmes Street.
 - ii. Further extension of the proposed water main on Winthrop Avenue and Holmes Street.
 - iii. Added one hydrant assembly near the intersection of High Street and Holmes Street.
 - iv. Corrected detail references.

Section 00300 (Form for General Bid) was also revised based on the above changes.

Attachments:

Section 00300 (Form for General Bid) Revised 02/07/2020
Sheet C-2 Revised 02/07/2020
Sheet C-3 Revised 02/07/2020

SECTION 00300

FORM FOR GENERAL BID

Ayer Department of Public Works
Ayer, Massachusetts
FY2020 Water and Drain Improvements

The following Bid is submitted to: Town of Ayer Department of Public Works
25 Brook Street
Ayer, MA 01432

By (Contractor Name): _____
(Address for Giving Notice): _____

A. The Undersigned proposes to furnish all labor and materials required for the FY2020 Water and Drain Improvements in Ayer, Massachusetts, in accordance with the accompanying plans and specifications prepared by The Ayer DPW for the contract price specified below, subject to additions and deductions according to the terms of the specifications.

B. This bid includes addenda

Number _____
Dated _____

C. BASE BID -The proposed contract price for the **Base Bid including Bid Items 1 through 16** complete is

_____ dollars (\$_____).
(in Words) (in Figures)

D. ADD ALTERNATE-The proposed contract price for the Add Alternate including Bid Item A1 complete is

_____ dollars (\$_____).
(in Words) (in Figures)

E. The subdivision of the proposed contract price is as follows:

BASE BID

Item No.	Quantity*	Brief Description of Item with Unit Bid Price in Words	Unit Bid In Figures	Amount In Figures
1	970 LF	8-Inch Diameter Ductile Iron Water Mains The Sum of \$ _____ _____	\$ _____	\$ _____
		Per Linear Foot		
2	3 EA	8-Inch Diameter Gate Valves and Boxes The Sum of \$ _____ _____	\$ _____	\$ _____
		Per Each		
3A	3 EA	Hydrant Assembly The Sum of \$ _____ _____	\$ _____	\$ _____
		Per Each		
3B	2 EA	Remove Existing Hydrant and Valve Box The Sum of \$ _____ _____	\$ _____	\$ _____
		Per Each		
4	16 EA	1-Inch Corporation Stops and Taps The Sum of \$ _____ _____	\$ _____	\$ _____
		Per Each		
5	16 EA	Curb Stops and Curb Boxes The Sum of \$ _____ _____	\$ _____	\$ _____
		Per Each		
6	350 LF	1-Inch Copper Service Pipe The Sum of \$ _____ _____	\$ _____	\$ _____
		Per Linear Foot		
7	1 LS	Temporary Water Service The Sum of \$ _____ _____	\$ _____	\$ _____
		Lump Sum		

Item No.	Quantity*	Brief Description of Item with Unit Bid Price in Words	Unit Bid In Figures	Amount In Figures
8	10 CY	Ledge/Boulder Excavation The Sum of \$ _____ _____	\$ _____	\$ _____
		Per Cubic Yard		
9	10 CY	Common Borrow to Replace Unsuitable Material The Sum of \$ _____ _____	\$ _____	\$ _____
		Per Cubic Yard		
10	280 CY	Gravel Subbase The Sum of \$ _____ _____	\$ _____	\$ _____
		Per Cubic Yard		
11	840 SY	Temporary Bituminous Pavement The Sum of \$ _____ _____	\$ _____	\$ _____
		Per Square Yard		
12	100 SY	Loam and Seed The Sum of \$ _____ _____	\$ _____	\$ _____
		Per Square Yard		
13	300 LF	12-inch HDPE Drain Pipe The Sum of \$ _____ _____	\$ _____	\$ _____
		Per Linear Foot		
14	155 LF	15-inch HDPE Drain Pipe The Sum of \$ _____ _____	\$ _____	\$ _____
		Per Linear Foot		

Item No.	Quantity*	Brief Description of Item with Unit Bid Price in Words	Unit Bid In Figures	Amount In Figures
15	1 Each	Precast Concrete Manhole - Drainage The Sum of \$ _____ _____	\$ _____	\$ _____
		Each		
16	7 Each	Precast Concrete Catch Basin The Sum of \$ _____ _____	\$ _____	\$ _____
		Each		

* Indeterminate quantities assumed for comparison of bids. Quantities are not guaranteed. Payment will be based on actual quantities installed/constructed.

ADD ALTERNATE

Item No.	Quantity*	Brief Description of Item with Unit Bid Price in Words	Unit Bid In Figures	Amount In Figures
A1	1 Each	Tree Box Filter The Sum of \$ _____ _____	\$ _____	\$ _____
		Each		

* Indeterminate quantities assumed for comparison of bids. Quantities are not guaranteed. Payment will be based on actual quantities installed/constructed.

- G. The undersigned agrees that, if selected as general contractor, he/she will within five days, Saturdays, Sundays and legal holidays excluded, after presentation thereof by the awarding authority, execute a contract in accordance with the terms of this bid and furnish a performance bond and also a labor and materials or payment bond, each of a surety company qualified to do business under the laws of the commonwealth and satisfactory to the awarding authority and each in the sum of the contract price, the premiums for which are to be paid by the general contractor and are included in the contract price.

The undersigned declares that the only persons or parties interested in this Bid as principals are as stated; that the Bid is made without any collusion with other persons, firms, or corporations; that all, the Contract Documents as prepared by The Ayer Department of Public Works and dated April 2018 have been carefully examined; that the undersigned is fully informed in regard to all conditions pertaining to the Work and the place where it is to be done, and from them the undersigned makes this Bid. These prices shall cover all expenses incurred in performing the Work required under the Contract Documents, of which this Bid Form is a part.

The time period for holding bids, where Federal approval is not required is 30 days, Saturdays, Sundays and legal holidays excluded, after the opening of bids.

The Bid Security accompanying this Bid shall be in the amount of 5 percent of the Bid. The Bid Security shall be sealed in a separate envelope from the Bid and then attached to the envelope containing the Bid.

If a Notice of Award accompanied by at least six unsigned copies of the Agreement and all other applicable Contract Documents is delivered to the undersigned within thirty days, excluding Saturdays, Sundays, and legal holidays after the actual date of the opening of the General Bids, the undersigned will within five days, excluding Saturdays, Sundays, and legal holidays, after the date of receipt of such notification, execute and return all copies of the Agreement and all other applicable Contract Documents to OWNER. The premiums for all Bonds required shall be paid by CONTRACTOR and shall be included in the Contract Price. The undersigned Bidder further agrees that the Bid Security accompanying this Bid shall become the property of OWNER if the Bidder fails to execute the Agreement as stated above.

The undersigned hereby agrees that the Contract Time shall commence twenty days following the Effective Date of the Agreement and that the Work will be substantially complete and completed and ready for final payment in accordance with paragraph the General Conditions on or before the dates or within the number of calendar days indicated in the Agreement. Work will be substantially complete within **100** calendar days after the date when the Contract Time commences to run provided in the General Conditions and completed and ready for final payment within **130** calendar days after the date when the Contract Time commences to run. The undersigned further understands that delays in completion of the Work will cause the OWNER to suffer damages and incur substantial costs, and will expose the OWNER to other substantial liabilities, and that if the selected Contractor shall neglect, fail or refuse to achieve

Substantial Completion or final completion of the Work within the times specified above, as such times may be extended pursuant to the provisions of the Contract Documents, the OWNER will hold the selected Contractor strictly liable for all such damages and any other damages, costs, expenses or liabilities sustained or incurred by the OWNER arising out of such delays, as further provided in the Agreement, or for any delay in achieving any other milestones set forth in the Contract Documents in accordance with the terms of the Agreement. The undersigned accepts the provisions of the Agreement as to liquidated damages in the event of failure to complete the Work on time in the amount of \$500 per day after substantial completion time limits and \$500 per day after final completion time limits.

In accordance with the above understanding, the undersigned proposes to perform the Work, furnish all materials and complete the work in its entirety in the manner and under the conditions required.

In comparison of Bids, alternates will be applied in the same order of priority as listed in the Bid Form. After determination of the Successful Bidder based on the responsiveness, responsibility, and other Factors set forth in the Instructions, the award may be made to said Successful Bidder on its Base Bid and any combination of its additive alternate Bids for which Owner determines funds will be available at the time of award.

The undersigned agrees that extra work, if any, will be performed in accordance with Article 10 of the General Conditions of the Contract and will be paid for in accordance with Article 11 of the General Conditions of the Contract.

The bidding and award of this Contract will be in accordance with M.G.L. Chapter 30, Section 39M.

The undersigned must furnish a 100 percent Performance Bond and a 100 percent Payment Bond with a surety company acceptable to OWNER.

Where indicated for amounts to be shown in both words and figures, in case of discrepancy, the amount shown in words shall govern.

The following documents are attached to and made a condition of this Bid:

- (a) This Bid Form in its Entirety.
- (b) Required Bid Security.
- (c) Required Experience Statement (Section 00405) with supporting data.

CERTIFICATIONS

Pursuant to M.G.L. Ch. 62C, sec. 49A, I certify under the penalties of perjury that I, to my best knowledge and belief, have filed all state tax returns and paid all state taxes required under law.

The undersigned hereby certifies that he/she is able to furnish labor that can work in harmony with all other elements of labor employed or to be employed on the work and that he/she will comply fully with all laws and regulations.

The undersigned further certifies under the penalties of perjury that this bid is in all respects bona fide, fair and made without collusion or fraud with any other person. As used in this subsection the word “person” shall mean any natural person, joint venture, partnership, corporation or other business or legal entity.

The undersigned further certifies under penalty of perjury that the said undersigned is not presently debarred from doing public construction work in the Commonwealth under the provisions of Section Twenty-nine F of Chapter Twenty-nine, or any other applicable debarment provisions of any other chapter of the General Laws or any rule or regulation promulgated thereunder.

Social Security Number or
Federal Identification Number

Individual or Corporate Name
(Print or Type)

By: _____
(Signature)

RESPECTFULLY SUBMITTED on _____, 20__

An Individual

By (Individual's Name) _____

(SEAL)

doing business as _____

Business address: _____

Phone No.: _____

A Partnership

By (Firm Name) _____

(SEAL)

(General Partner) _____

Business address: _____

Phone No.: _____

A Corporation

By (Corporation Name) _____ (Corporate Seal)

(State of Incorporation) _____

By (Name and Title of Person Authorized to Sign) _____

Attest (Secretary) _____

Business address: _____

Phone No.: _____

A Joint Venture

By (Name) _____ (SEAL)

(Address) _____

Phone No.: _____

By (Name) _____ (SEAL)

(Address) _____

Phone No.: _____

By (Name) _____ (SEAL)

(Address) _____

Phone No.: _____

(Each joint venture must sign. The manner of signing for each individual, partnership and corporation that is a party to the joint venture should be in the manner indicated above).

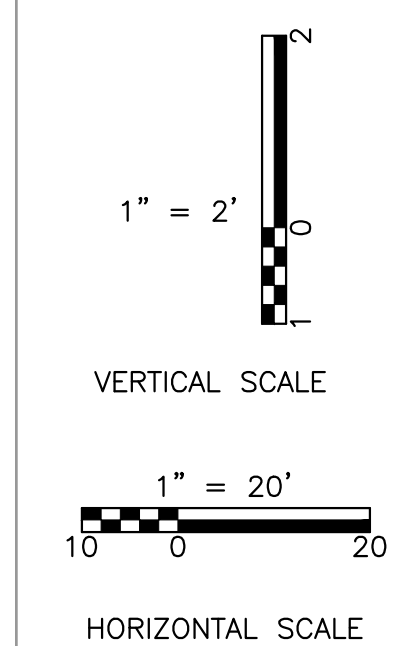
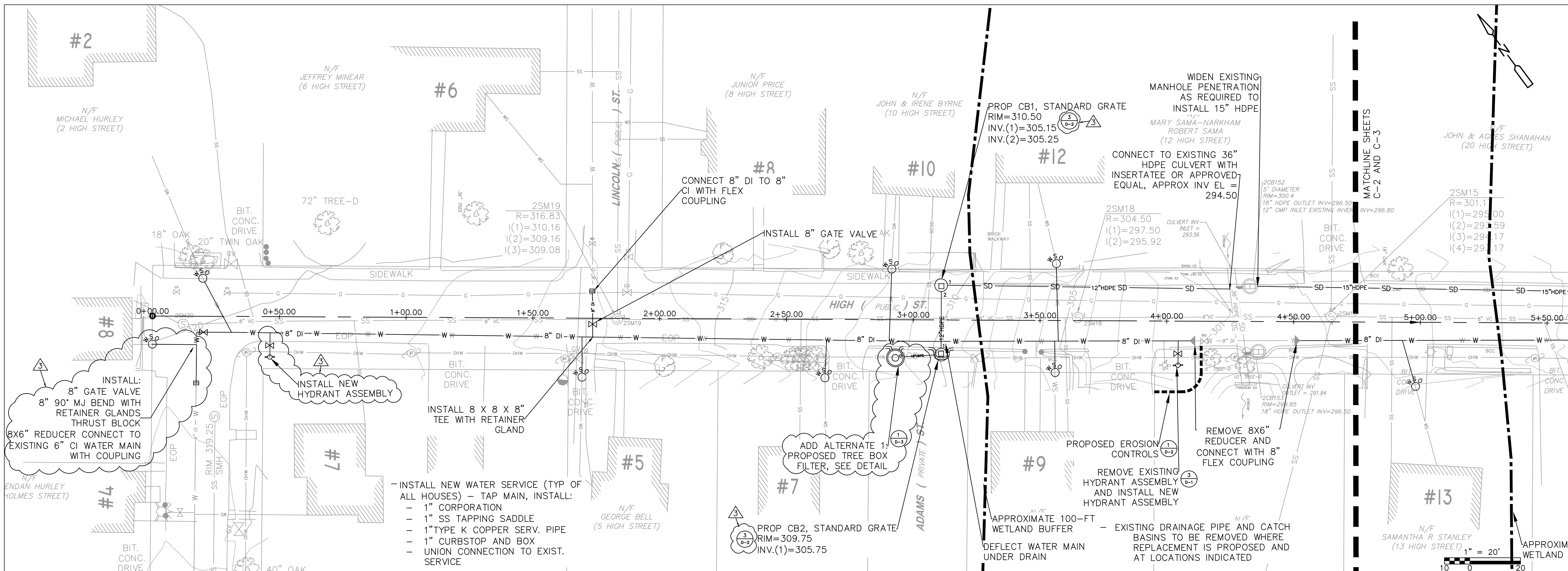

CERTIFICATION:
STATUS:

ENGINEER:

Ayer DPW
25 Brook Street
Ayer, Massachusetts

REVISIONS:

MARK	DATE	DESCRIPTION
1	01/21/2020	ISSUED FOR PERMITTING
2	01/22/2020	ISSUED FOR BIDDING
3	02/07/2020	CHANGES PER ADDENDA 1

PROJECT:
**FY2020 WATER AND DRAIN IMPROVEMENTS
AYER, MA**

FILE NAME:
S:\7-Water\Water Main
Improvements\High St Water
Main\Drawings

AUTHOR: DELANEY YORK
DRAFTER: DELANEY YORK
CHECKED BY: DAN VAN SCHALKWYK
DATE: FEBRUARY 2020

SHEET TITLE:
**PROPOSED
CONDITIONS
HIGH STREET**

SHEET:
C-2

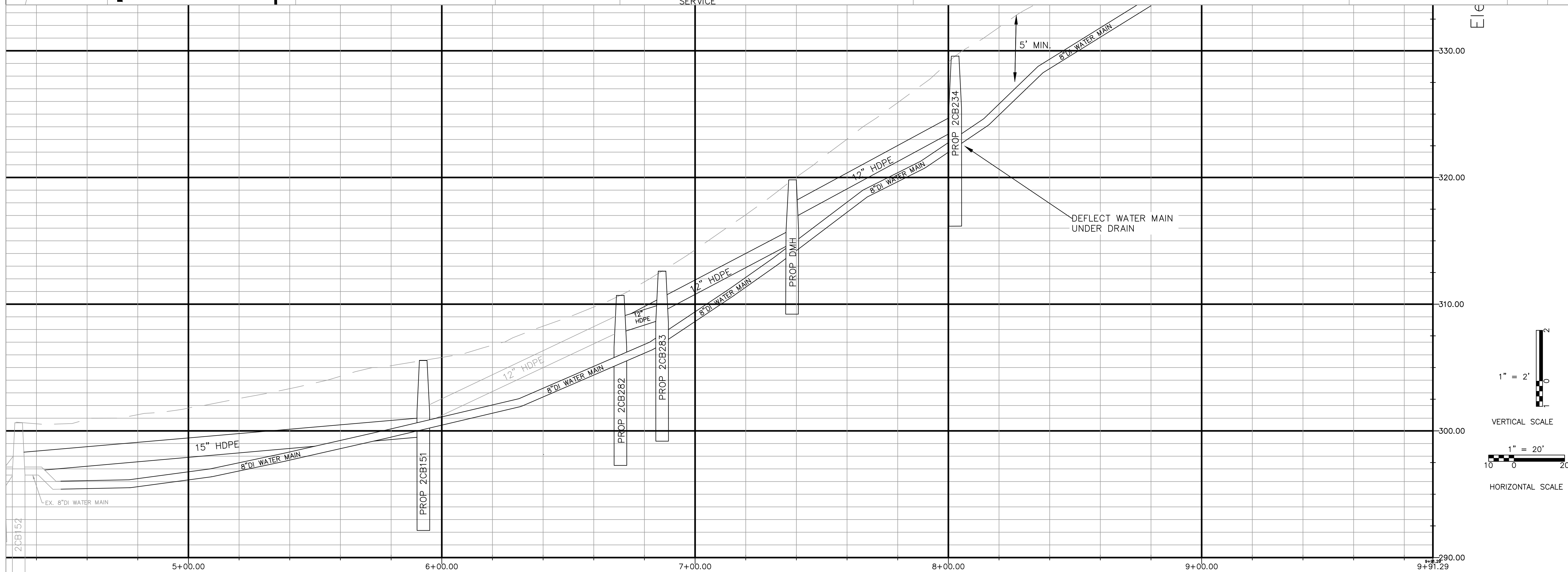
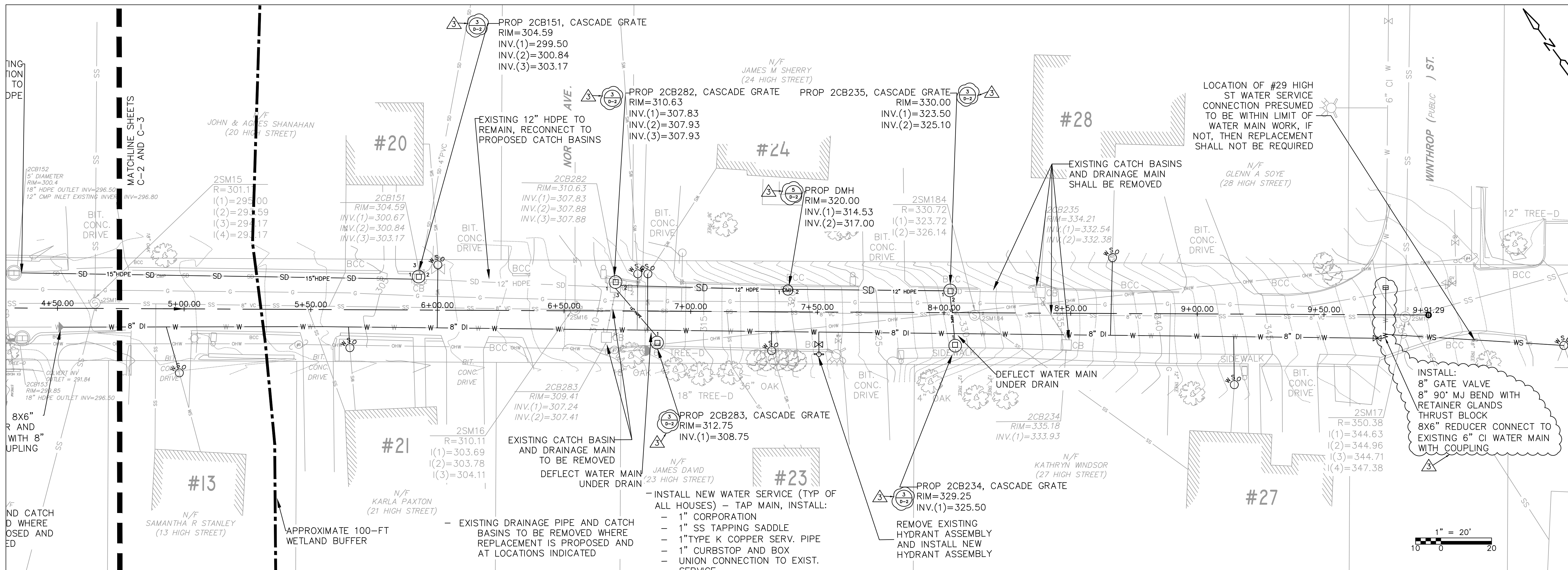

CERTIFICATION:

STATUS:

ENGINEER:

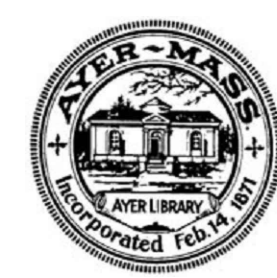

Ayer DPW
25 Brook Street
Ayer, Massachusetts

REVISIONS:

MARK	DATE	DESCRIPTION
1	01/21/2020	ISSUED FOR PERMITTING
2	01/22/2020	ISSUED FOR BIDDING
3	02/07/2020	CHANGES PER ADDENDA 1

PROJECT:

FY2020 WATER AND DRAIN IMPROVEMENTS
AYER, MA

FILE NAME:
S:\7-Water\Water Main Improvements\High St Water Main Drawings

AUTHOR: DELANEY YORK
DRAFTER: DELANEY YORK
CHECKED BY: DAN VAN SCHALKWYK
DATE: FEBRUARY 2020

SHEET TITLE:
**PROPOSED CONDITIONS
HIGH STREET**

SHEET:
C-3

